

Timeless residential design with aluminium sliding and folding sliding systems





Contents

Aluminium	04	
	06	Create new spaces – With sliding systems from Schüco
	07	Schüco Panorama Design sliding systems
Energy	08	
	10	Saving energy
Design	12	
	14	Diverse opening options
	15	Sliding doors
	15	Lift-and-slide doors
	16	Tilt/slide (PASK) doors
	17	Folding sliding doors
	17	Unlimited choice of colours for all sliding systems
Comfort	18	
	20	Schüco e-slide – The convenient way to operate sliding doors
	21	Energy through automation
Security	22	
	24	Integrated security
Overview	26	
	27	Aluminium sliding and folding sliding systems from Schüco

Aluminium: what the future is made of.

A natural material. Enables precision in fabrication. Particularly durable. Benefits which make aluminium the material of choice. For example: with sliding doors that not only flood rooms with light, but also help to define the character of a building.



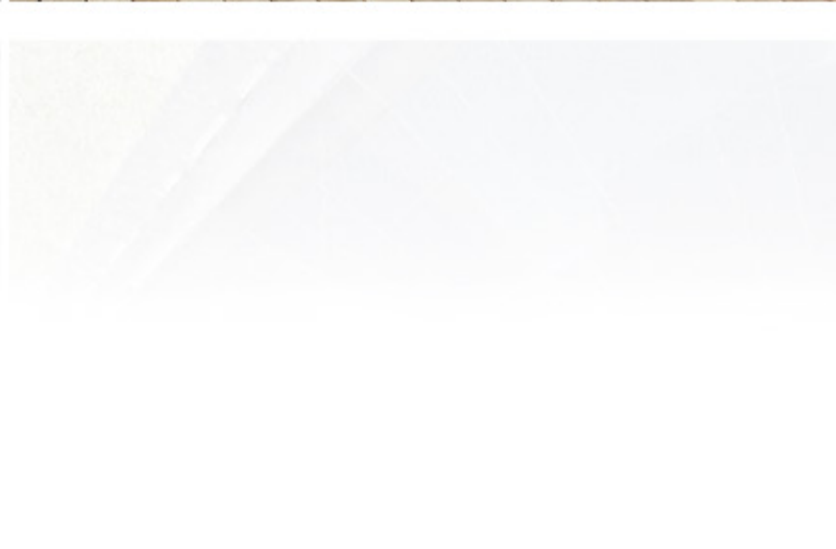



More light and space for a sense of wellbeing

Create new spaces – With sliding systems from Schüco

Sunlight is vitalising and transmits a feeling of wellbeing. It can be utilised to the full with sliding and folding sliding doors made from aluminium. Thanks to the high stability of aluminium, buildings can be designed with narrow profiles and particularly large areas of glass, providing maximum transparency and light penetration.

Who does not wish they could extend their office or living space at the turn of a handle? Highly thermally insulated sliding and folding sliding doors create new spaces: the conservatory becomes one with the garden, whilst the balcony and patio extend the living space.

The non-insulated sliding systems from Schüco offer a wide range of new design concepts for use indoors. Both system constructions can be combined seamlessly thanks to their design.

How does this benefit you?

- Smooth operation
- Saves space
- Burglar-resistant
- Range of opening types
- Range of colours

Schüco Panorama Design sliding systems



Maximum transparency with minimal profile face widths



iF gold award winner 2012

The Schüco Sliding System ASS 77 PD won the coveted iF product design award for 2012. In addition, the system won the golden trophy in the "buildings" category of the 100 best products from all the iF competitions.



reddot design award
best of the best 2012

red dot award: product design – best of the best 2012

In 2012, the Schüco Sliding System ASS 77 PD.SI not only won the red dot award for product design; it also triumphed as one of the best designs of the year in the red dot "best of the best" award.

Schüco Panorama Design (PD) sliding systems make large-scale sliding units with maximum transparency possible. Slender profile face widths and ideal thermal insulation for every requirement impress architects and clients alike.

The Panorama Design sliding systems are suitable for different climate zones and are available in 3 variants:

Schüco ASS 77 PD.SI – system with maximum thermal insulation

Schüco ASS 77 PD.HI – highly thermally insulated system

Schüco ASS 77 PD.NI – non-insulated system

The best way to energy efficiency – the door.

In winter, the cold stays outside. In summer, the heat. Sliding doors from Schüco are thermally insulated to passive house standard and therefore create an internal climate that is pleasant at all times. For a clear conscience when heating your home. For low air conditioning costs in high outside temperatures. In short: for responsible use of energy.





Saving energy

Saving energy does not just mean contributing towards climate protection; it is also about saving money. In the face of soaring energy costs, this is in the interest of every client.



Saving energy with thermally insulated sliding systems

Sliding and folding sliding doors must meet high requirements in terms of thermal insulation – especially if large constructions are required. This creates a high level of comfort in your home by maintaining a constant, agreeable room climate; it also saves valuable energy and prevents high costs. And this is not only

on cold days, but also in summer. Then, the heat stays outside and the cost of air conditioning can therefore be considerably reduced.

Optimum comfort and enormous potential for saving energy – a perfect match.

Reduce energy costs with highly thermally insulated sliding systems

The aluminium profiles, which are thermally broken by insulating bars, are fitted with isolators and efficient gaskets. Together with high quality insulating glass, the best thermal insulation results are achieved. The ASS 70.HI

lift-and-slide door and the ASS 80 FD.HI folding sliding door therefore fulfil the requirements of the EnEV energy saving regulations with ease.

Foam insulating bars in vents and outer frame profiles guarantee the best thermal insulation

Smaller face widths with maximum vent sizes ensure transparency

Flush threshold for a high level of comfort

Additional insulation zone for even better thermal insulation

PVC-U hollow chamber profiles for more stability and thermal insulation

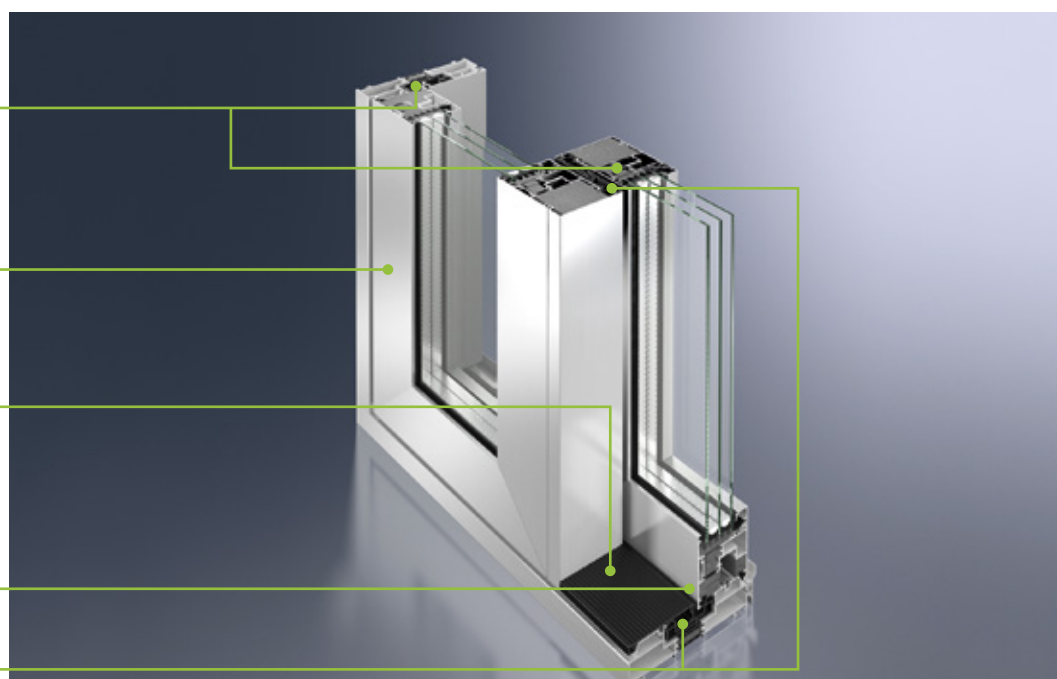

Schüco ASS 70.HI (Aluminium Sliding System) highly thermally insulated sliding system

Additional insulation zone for even better thermal insulation

Foam insulating bars in vents and outer frame profiles guarantee the best thermal insulation

Smaller face widths with maximum vent sizes ensure transparency

Attractive design with rounded profile edges

Either with a continuous outer frame for a high degree of weathertightness or a flush threshold for a high level of comfort

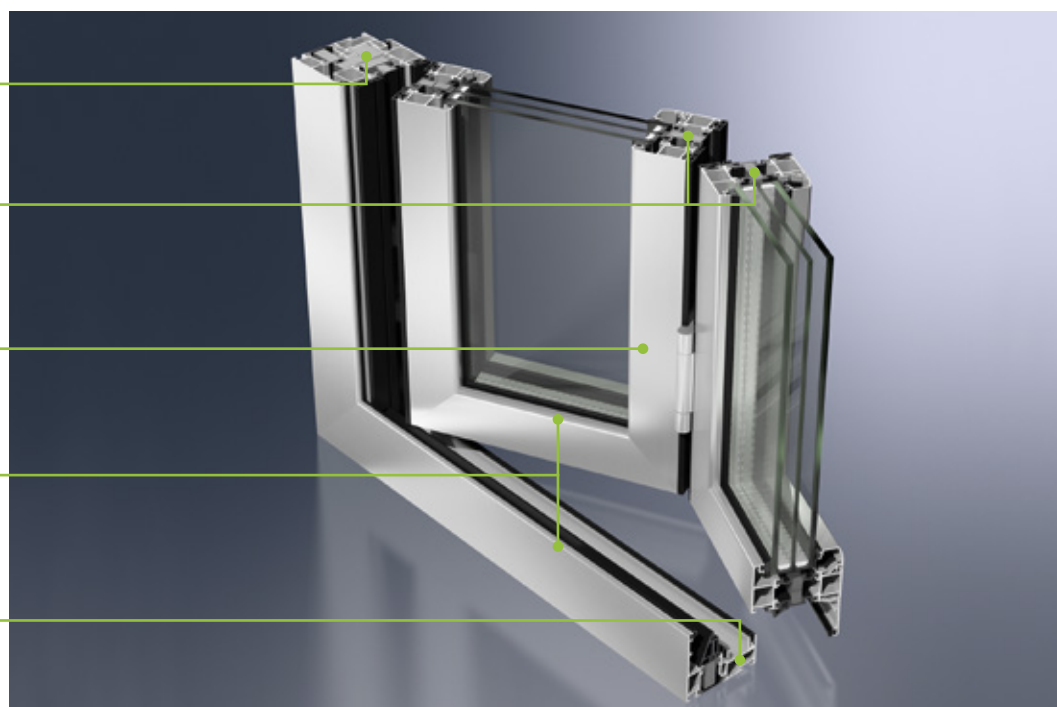

Schüco ASS 80 FD.HI highly thermally insulated folding sliding system

Designs are created almost automatically.

Visible individuality at first sight. Schüco offers you the opportunity to mix the form, function, colour and technology of your sliding doors as desired – and then combine them harmoniously with your windows. In this way, each building has an unmistakable character: its own.





Diverse opening options

Schüco sliding systems offer perfect functionality and the diverse opening options open up special design possibilities:

- Sliding doors
- Lift-and-slide doors
- Tilt/slide (PASK) doors
- Folding sliding doors

Thanks to the wide choice of colours and profiles, the transparent sliding constructions can be perfectly tailored to the architecture of a house or conservatory both inside and out. This creates an harmonious overall appearance and visually striking accents.

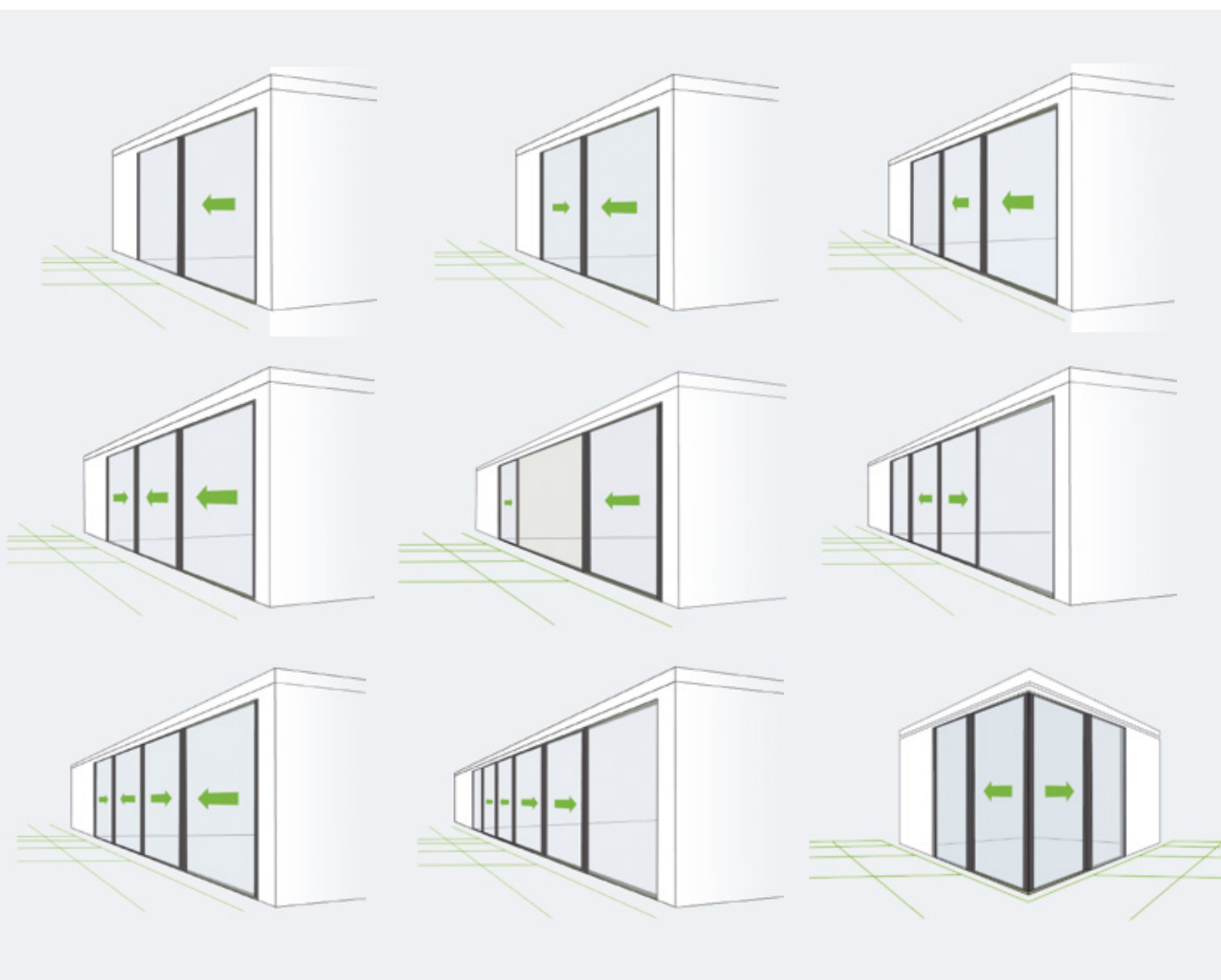

Choice of possible opening options for sliding and lift-and-slide doors
(scope dependent on sliding system)

Sliding doors



Transparent crossover
to the outside area

A door is required that can simply be pushed to one side when necessary and creates generous openings of up to two-thirds of the unit width. Schüco sliding doors operate almost silently in corrosion-free stainless steel tracks.

All sliding units run in a single plane, with no unsightly vent protruding into the room. The scope of installation ideas is considerably greater thanks to sliding doors from Schüco. It is possible to combine up to six glazed frames depending on requirements.

Sliding units are also an ideal solution for dividing spaces indoors while retaining flexibility and transparency. The variety of colours is so great that you are guaranteed to find the right colour for the setting.

Lift-and-slide doors

It is surprising how easy a lift-and-slide door made from aluminium profiles is to move. When closed, the door is perfectly weather-tight, providing excellent thermal insulation and noise reduction, while its burglar-resistant properties ensure your personal security.

Lift-and-slide doors must be opened to one side or from the middle. Up to three tracks allow large opening widths and therefore flexible options for creating living spaces that are flooded with light.



Loft apartment with
exclusive views



Tilt/slide (PASK) doors



Tilt/slide: the ideal combination of sliding door and turn/tilt window is practical and simple to operate. For ventilation purposes, the vent of the tilt/slide window doors alone can be tilted or the entire area can be opened up very easily. Tilt/slide vents are stylishly flush-fitted in the frame units on the outside and face-fitted on the inside, thereby providing optimum weathertightness.

Tilt/slide (PASK) door in the conservatory



Tilt/slide (PASK) door closed



Tilt/slide (PASK) door in tilt position



Tilt/slide (PASK) door open

Folding sliding doors



Folding sliding doors

Folding sliding doors from Schüco are truly amazing space savers. They allow entire glass walls to be almost completely opened. The individual units are simply folded into a small space and pushed to the side – quickly and compactly. There are two options available depending on the area of use:

Highly thermally insulated folding sliding doors for external use

The door leaf stack for this thermally insulated door can be folded inwards or outwards very easily and moved to the right and/or left. The door leaves roll almost silently on roller carriers. They are securely guided at the top and at the bottom. This creates the ideal connection between the interior and exterior.

Non-insulated folding sliding doors for use indoors

The non-insulated folding sliding door is the ideal choice in areas in which no additional thermal insulation is required. The door system can be opened fully to extend living spaces and offices.

Unlimited choice of colours for all sliding systems

When it comes to sliding systems for doors and windows, there are no limits to the choice of colours.

The profile surfaces can be designed in different colours inside and outside to satisfy individual requirements. Your specialist dealer will be happy to give you personal advice in this regard.



With Schüco, comfort is fully automatic.

Increased comfort in the home thanks to building automation. Your little finger is all you need to open or close large doors. One look is all you need to check that all doors are closed. And one call to your Schüco partner is all you need to increase your quality of life even further with Schüco sliding systems.







Understated design combined with intelligent technology. The Schüco Sliding System ASS 77 PD and the Door Control System (DCS)

Schüco – The convenient way to operate sliding doors

Operated at the touch of a button

The more smoothly sliding doors operate, the easier they are to use. To this end, we have developed e-slide technology. This allows leaf weights of up to 500 kg or units measuring 3.5 x 3.2 metres to be lifted fully automatically, very quietly and quickly. Children, the elderly and the comfort-conscious in particular will appreciate this. The concealed e-slide automatic function is operated using a keypad on the leaf, a wall-mounted switch or centrally, if it is integrated in the building management system.

Schüco e-slide is fully automatic for sliding and lift-and-slide installations. Thanks to intelligent software, the e-slide drive has integrated anti-finger trap protection.

No chance of being locked out

Inadvertently locked out on the balcony or patio? Not with the fingerprint reader. With this biometric system integrated outside in the door profile, the lift-and-slide door is unlocked automatically by passing a finger over the thermal strip. Assuming, of course, that the fingerprint has first been logged in the system. There is no chance of unauthorised modification, providing secure protection against unwanted visitors.

Energy through automation

The automatically-controlled building envelope is a topic with a great future. Numerous functions such as ventilation, regulating room climate, shading, security and generating energy must be combined to optimise energy consumption. This is achieved with automatic opening and closing systems for sliding systems that control natural ventilation cycles, as well as daylight and sunlight-dependent shading systems, which ideally are coupled with internal lighting, heating and climate control.

Centrally controlled windows and doors can be used, on the one hand, for generating energy and, on the other hand, for night-time cooling of the building via the controlled opening of windows.

It is a stated aim of Schüco that all active elements in a building envelope be networked electronically and controlled automatically. This allows for the full energy efficiency potential of the building envelope to be exploited. The radio-controlled Schüco Wireless Control System allows for automation without the need for cabling, making it suitable for building modernisation.

Using communication modules such as iPad, iPhone, Blackberry etc. as a means of control opens up new possibilities for operation, setting and use of opening units as well as for solar shading, anti-glare protection, light control and climate regulation.



Example: control using an iPad

Security: the door is the key.

Protected day and night. With Schüco, security is not just a feeling, but a certainty. Through innovative technology that cannot be seen, but can be felt. When fingers can no longer be trapped. When doors close and lock automatically. And when insurance is reduced in price as a result.





Integrated security

Schüco aluminium sliding systems fulfil almost every requirement in terms of functionality, comfort and design - and simultaneously meet high security requirements.

One substantial advantage is the high material stability of the aluminium profiles, which contributes to increased burglar resistance. Depending on the sliding system fittings used, a burglar resistance classification of up to resistance class 2 (RC2) is possible.

A suitable security system is also available for electrically operated sliding units: Schüco e-Slide features reliable anti-finger trap protection which is based on intelligent software.

This ensures that the vent immediately reverses if it encounters an obstacle such as a person or an object. Any such obstacle can even be recognised via an optional infrared sensor as soon as it comes within a specified distance of the system.

Resistance classes in burglar resistance

RC1	RC2
<p>Components in this security class provide basic protection against attack using body weight, such as kicking, flying kick, shoulder charge, lifting upwards and tearing out.</p>	<p>Opportunist burglars also use simple tools such as screwdrivers, pliers and wedges to try to break into locked and bolted building components.</p>



Monitoring of opening and closing

And just in case you would like to make doubly sure: on request, Schüco offers integrated monitoring of opening and closing with a confirmation function for electronic locking controls when leaving the home.

This monitoring system also has an interface which can be integrated into the building automation and can be combined with alarm systems. In this way, you can customise increased security for your home and family.

Added security
through integrated monitoring of
opening and closing















Aluminium sliding and folding sliding systems from Schüco

Systems	Vent dimensions: Max. width/max. height in mm	Maximum vent weight in kg	Vent face width in mm	Basic depth of outer frame in mm	Glass thickness in mm	Resistance class (RC)	Number of tracks	Fittings
Sliding units for doors and windows								
Insulated								
ASS 39 SC	1500 ¹ / 2600 ²	160	From 74	From 60	24 – 28	2	1, 2 or 3	Gearbox handle / retaining catch / door pull
ASS 39 SC TipTronic	1500 ¹ / 2600 ²	160	From 74	From 60	24 – 28		2	Operating switch/rocker switch/indicator panel
ASS 43 / 48	2500 ¹ / 2600 ²	230	From 75	From 85	13 – 32	2	1, 2 or 3	Sliding handle/retaining catch
ASS 50	3000 ¹ / 3000 ²	300	From 84	From 120	8 – 32	2	1, 2 or 3	Sliding handle/retaining catch/door pull
ASS 77 PD.HI	3200 ¹ / 3500 ²	500	From 30	From 200	Up to 60	2	2 or 3	Wall-mounted switch
ASS 77 PD.SI	3200 ¹ / 3500 ²	500	From 30	From 200	Up to 60	2	2	Wall-mounted switch
Non-insulated								
ASS 28 SC.NI	1800 ¹ / 2500 ²	160	From 57	From 50	6 and 20		2, 3	Gearbox handle / retaining catch / door pull
ASS 32.NI	1400 ¹ / 3000 ²	80	From 69	From 50	4 – 18		2, 3	Gearbox handle / retaining catch
ASS 32 SC.NI	1800 ¹ / 2500 ²	160	From 53	From 50	6 – 8 and 24		2, 3	Gearbox handle / retaining catch / door pull
ASS 39 PD.NI	2000 ¹ / 3400 ²	270	From 38	From 107	Up to 32		2, 3	Sliding handle/retaining catch/door pull
ASS 50.NI	3000 ¹ / 3000 ²	150	From 89	From 120	8 – 32	2	2	Sliding handle/retaining catch/door pull
ASS 77 PD.NI	3200 ¹ / 3500 ²	500	From 30	From 200	Up to 60	2	2	Wall-mounted switch
Lift-and-slide units for doors and windows								
Insulated								
ASS 50	3000 ¹ / 3000 ²	400	From 84	From 120	8 – 32	2	1, 2 or 3	Crank handle
ASS 50 e-slide	3000 ¹ / 3000 ²	250	From 84	From 120	8 – 32		2	Operating switch
ASS 70.HI	3000 ¹ / 3000 ²	400	From 88	160	Up to 52	2	1, 2 or 3	Crank handle
ASS 70.HI e-slide	3000 ¹ / 3000 ²	250	From 88	From 160	Up to 52		2	Operating switch
Non-insulated								
ASS 50.NI	3000 ¹ / 3000 ²	150	From 89	120	8 – 32	2	2	Crank handle
Tilt/slide (PASK) doors								
Can be constructed with all Schüco AWS window series	2200 ¹ / 2500 ² depending on series	200 depending on series	From 84.5 depending on series	From 50 depending on series	Up to 67 depending on series	Up to 2 depending on series	1	Window handle / tilt/slide (PASK) handle/ crank handle
Folding sliding doors								
Insulated								
ASS 70 FD	1200 ¹ / 3000 ²	100	From 54	70	6 – 45	2		Door handle / folding handle/window handle
ASS 80 FD.HI	1200 ¹ / 3000 ²	100	From 50	80	Up to 53	2		Door handle / folding handle/window handle
Non-insulated								
ASS 50 FD.NI	1000 ¹ / 2200 ²	55	From 60	50	8 – 30			Door handle / folding handle

¹Depending on vent height.²Depending on vent width.

Range of feature handles

Door pulls for tilt/slide (PASK) windows and doors				Door pulls for sliding doors			Crank handles for lift-and-slide doors			
Tilt/slide (PASK) doors with cavity fitted gearbox	With profile cylinder recess up to 130 kg	Tilt/slide (PASK) doors up to 200 kg	Lockable tilt/slide (PASK) doors	Door pull, inside only	With profile cylinder recess and flush handle	With profile cylinder recess inside and outside	Flush handle outside	With profile cylinder recess and flush handle	With profile cylinder recess inside and outside	Removable
										

Aluminium folding and sliding doors



Aluminium sliding and folding sliding doors from Schüco impress with their versatility. Whether they are used outdoors as spacious openings for terraces and balconies or indoors as transparent room dividers, they can always be relied on to make a design statement. At the same time, energy efficiency, fittings and design of the highest order are a matter of

course – and in terms of individual solutions, the sliding and folding sliding doors fulfil every requirement. A further benefit is that all units can be easily combined with other Schüco systems, e.g. with windows and conservatories.

Schüco International KG

www.schueco.com

Get the latest from the social networks at: www.schueco.de/newsroom

Schüco – System solutions for windows, doors and façades

Together with its worldwide network of partners, architects, specifiers and investors, Schüco creates sustainable building envelopes which focus on people and their needs in harmony with nature and technology. The highest demands for design, comfort and security can be met, whilst simultaneously reducing CO₂ emissions through energy efficiency, thereby conserving natural resources. The company and its Metal and PVC-U divisions deliver tailored products for newbuilds and renovations, designed to meet individual user needs in all climate zones. With 4800 employees and 12,000 partner companies, Schüco is active in 78 countries and achieved turnover of 1.5 billion euros in 2013. For more information, visit www.schueco.com.

SCHÜCO



BI-FOLD DOOR FACTORY

The Common, West Drayton UB7 7HQ

0800 999 5575

0330 999 5575

info@bifolddoorfactory.co.uk

www.bifolddoorfactory.co.uk